

REVISIONS:

DATE:	DESCRIPTION:	BY:

DATE: 03/19/2025

APPROVED BY: R. E. Z.

DRAWN BY: RANDY

**G.I.S. MAPPING**  
for the  
**BOROUGH OF SWISSVALE**  
situate in  
ALLEGHENY COUNTY, PA

**SCHLEY AVENUE SEWERLINE REPLACEMENT**

GLENN ENGINEERING & ASSOCIATES, LTD.  
Registered Engineers - North Huntingdon, PA

SCALE: 1" = 20'

SHEET SITE

NOTE: Sewer lateral locations are approximate and MUST be field verified.

Plan is Rotated 64.4248°

**GLENN ENGINEERING**

PERMITS/PAID ONE CALL SYSTEM 1-800-242-1776

IN ACCORDANCE WITH ACT 387 OF THE GENERAL ASSEMBLY'S ALL UTILITY COMPANIES ARE TO BE NOTIFIED THREE (3) DAYS BEFORE THE COMMENCEMENT OF ANY WORK. THE RESPONSIBILITY OF THE CONTRACTOR TO VERIFY THE ACCURACY OF THE LOCATION AND DEPTH OF ALL UTILITIES BEFORE ANY CONSTRUCTION AND MUST BE FIELD VERIFIED.

ENGINEER ASSUMES NO RESPONSIBILITY FOR UTILITIES LOCATIONS, UTILITY LOCATIONS SHOWN ON THIS PLAN ARE FOR GENERAL INFORMATION ONLY AND ARE NOT TO BE CONSIDERED AS COMPLETE OR ACQUIRABLE.





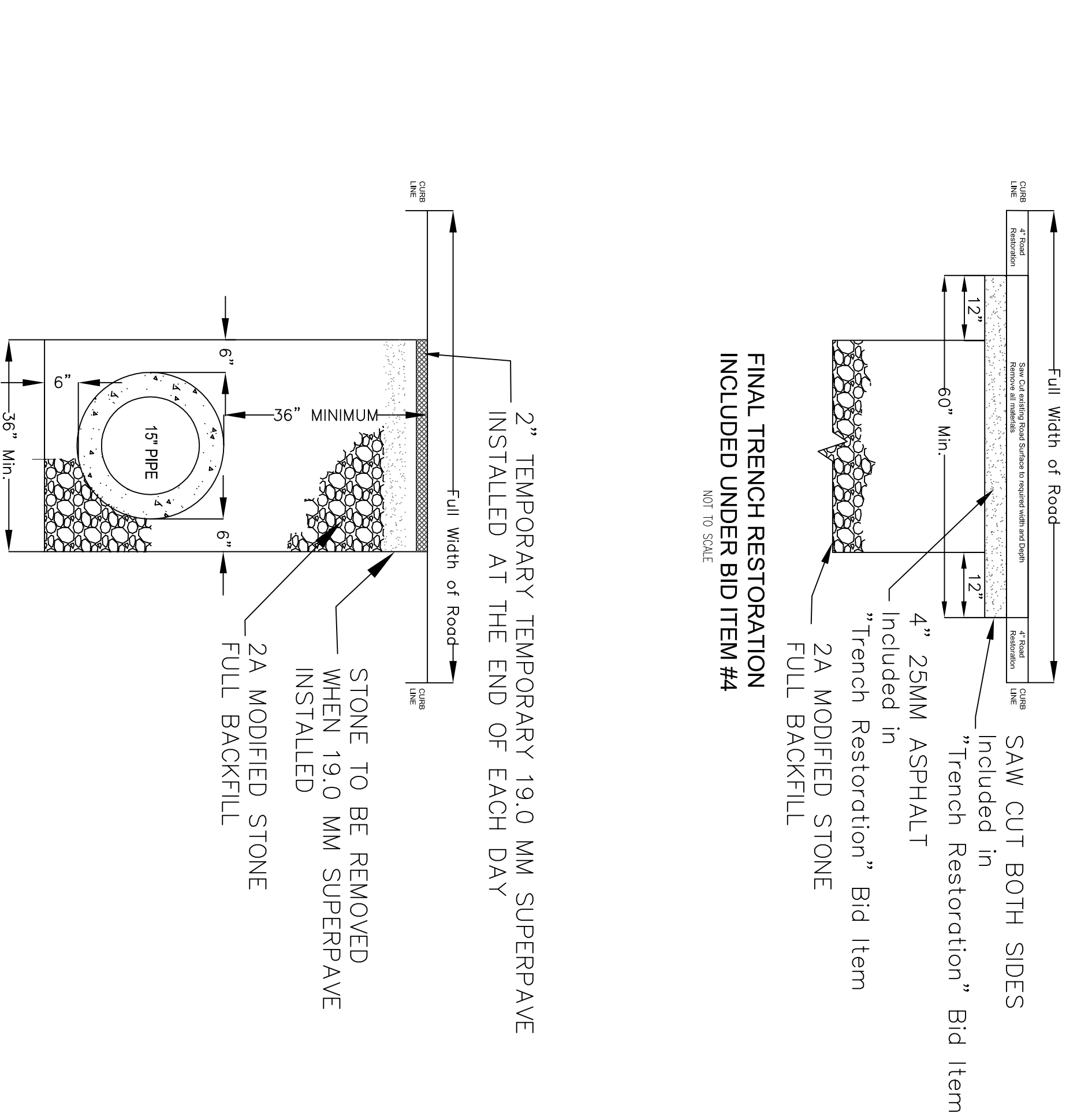
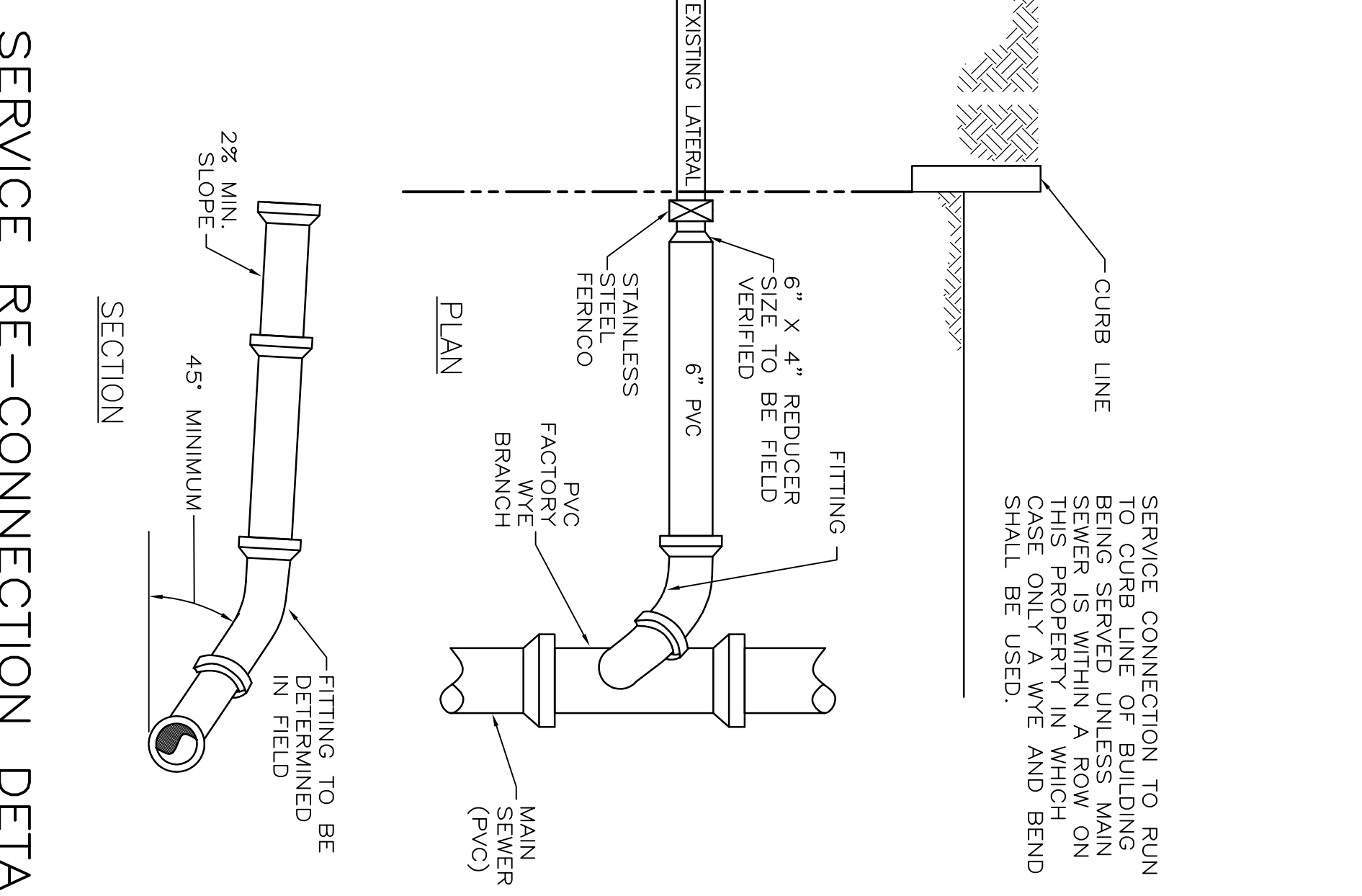
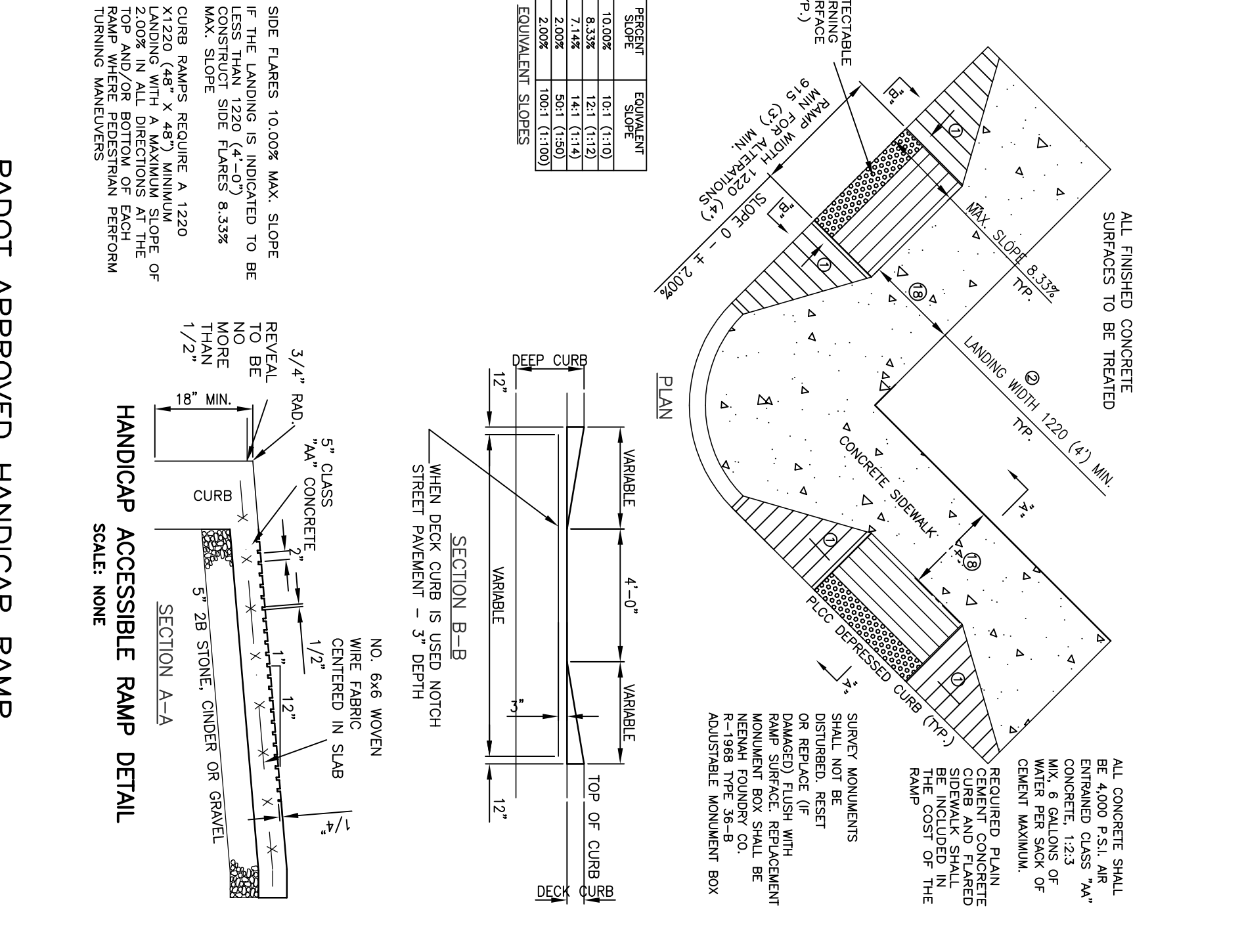
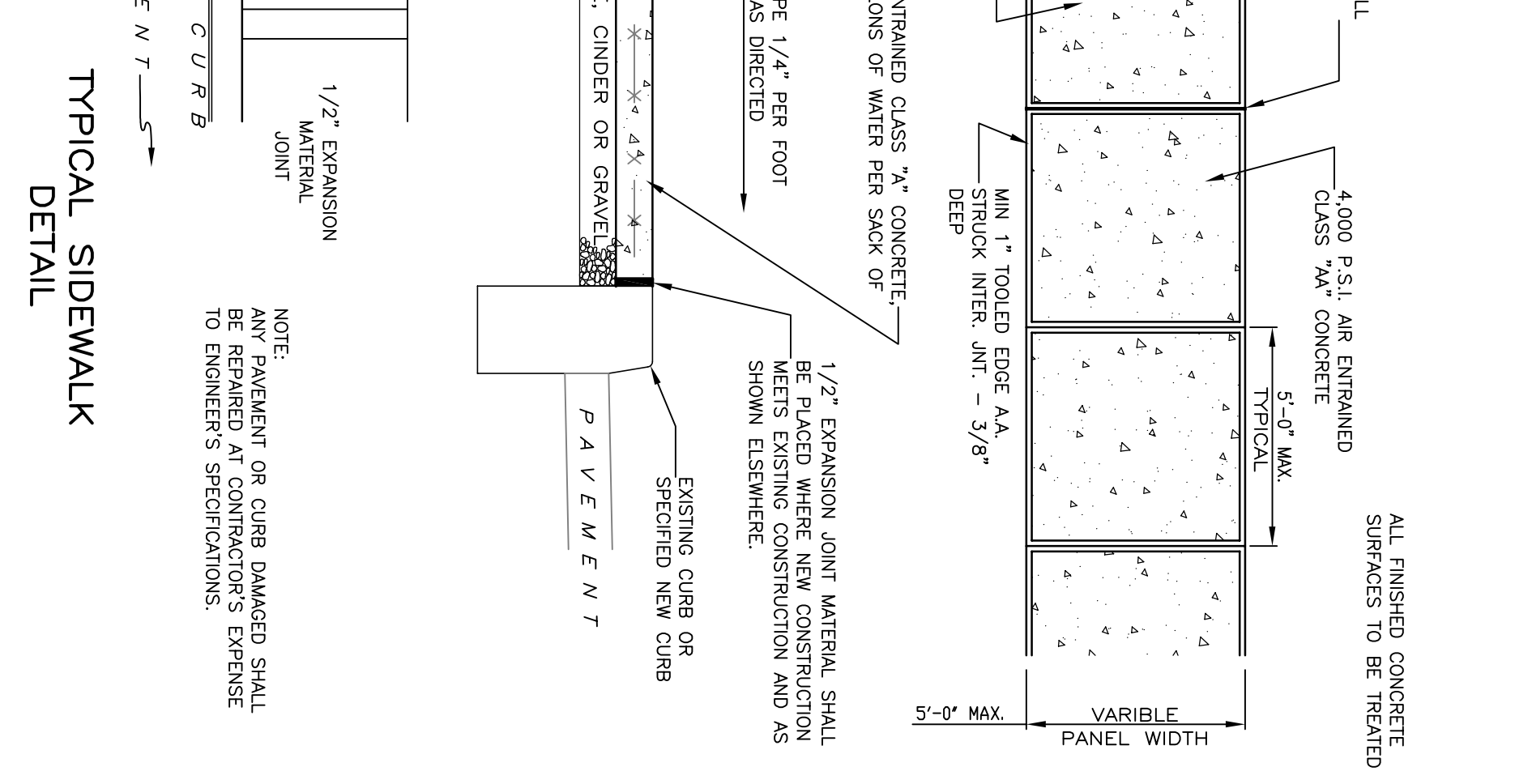
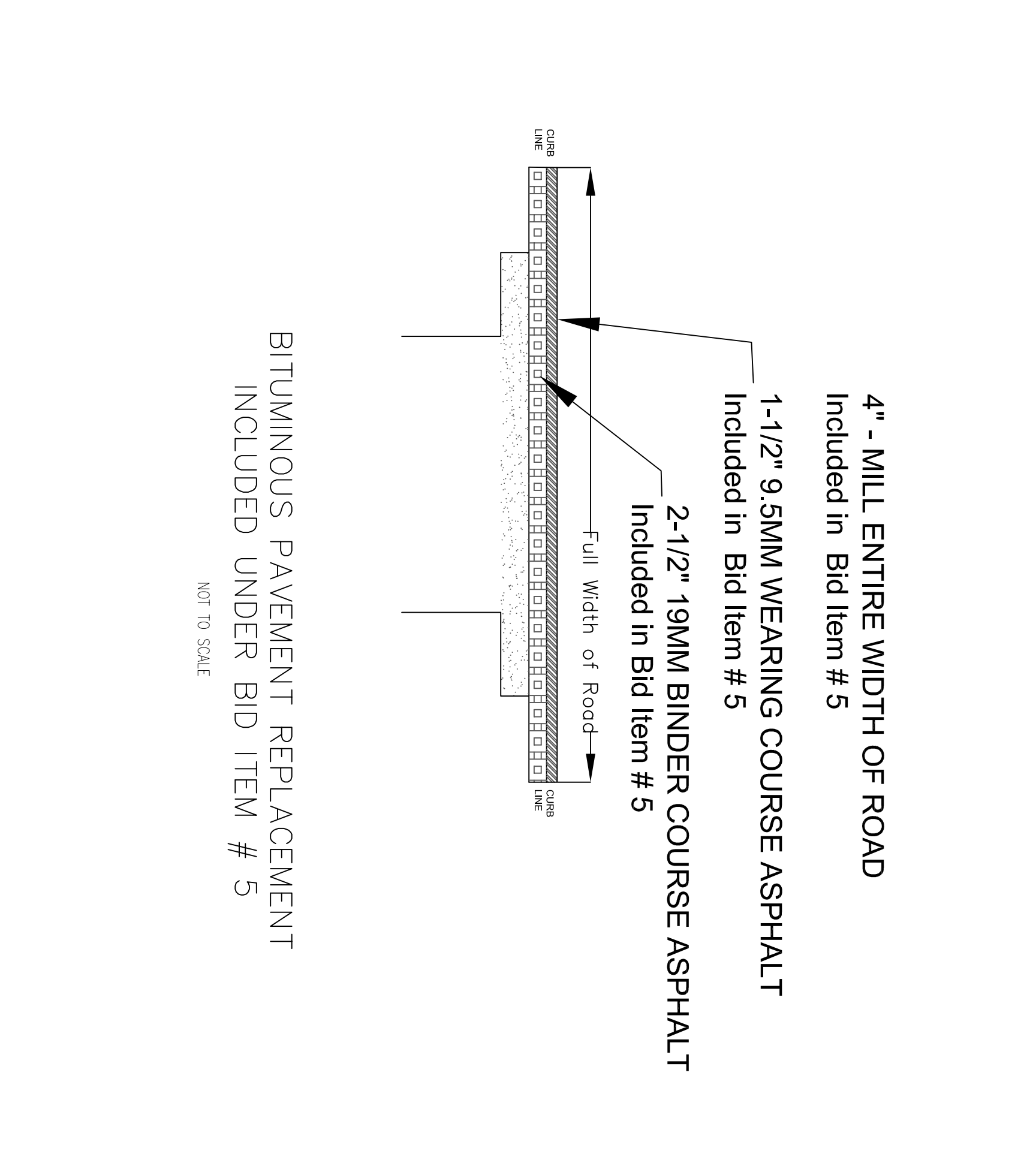
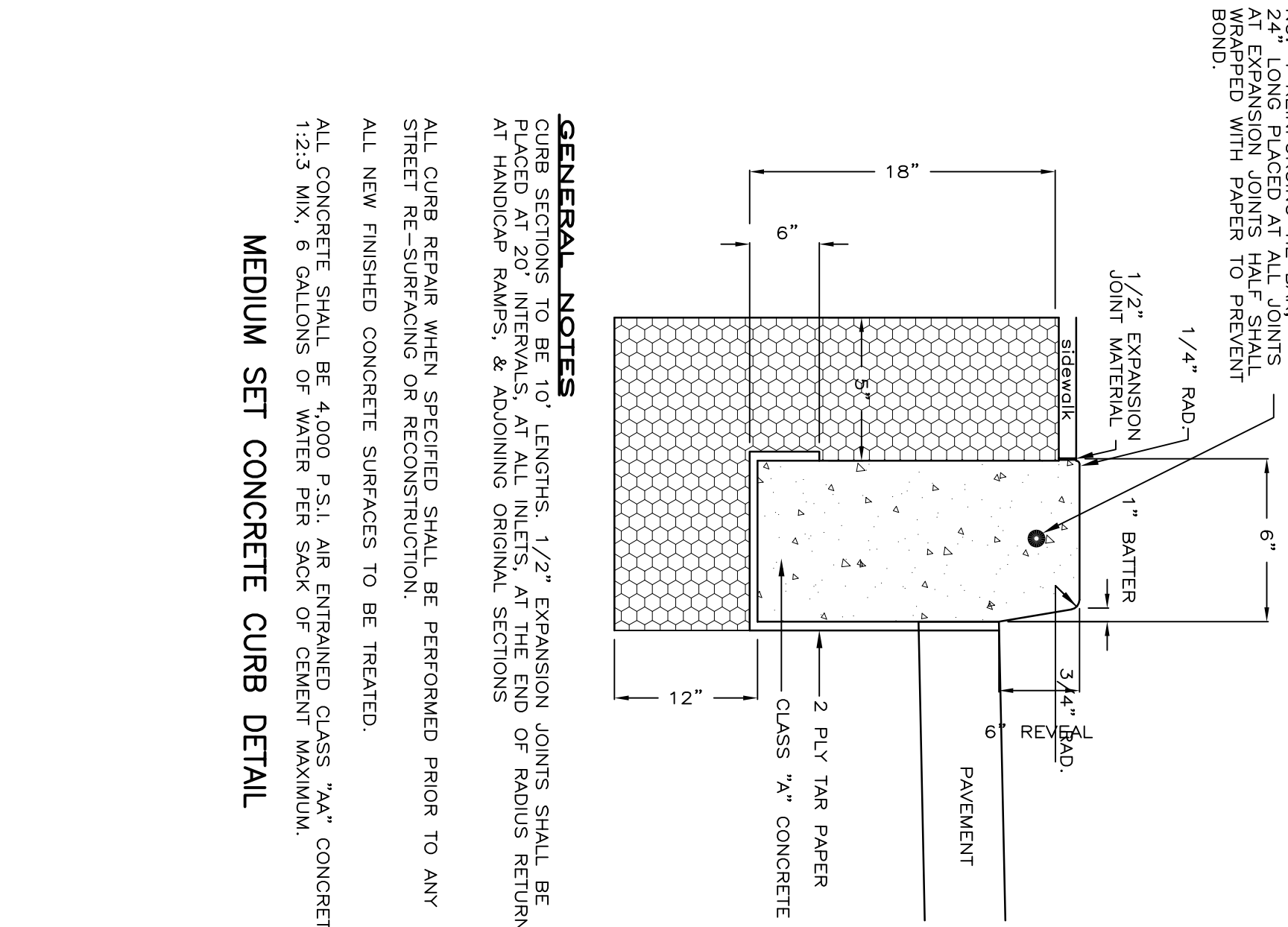
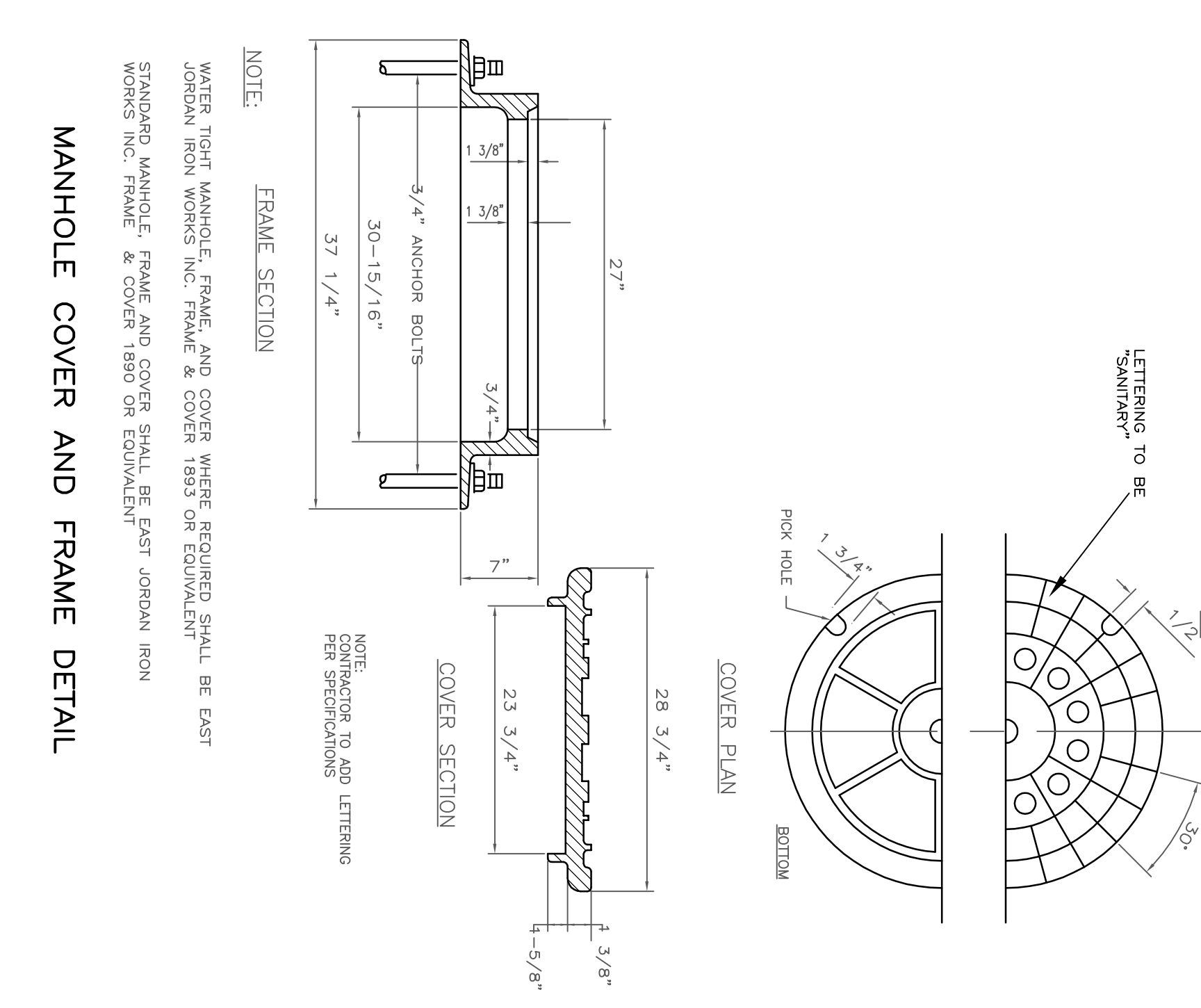
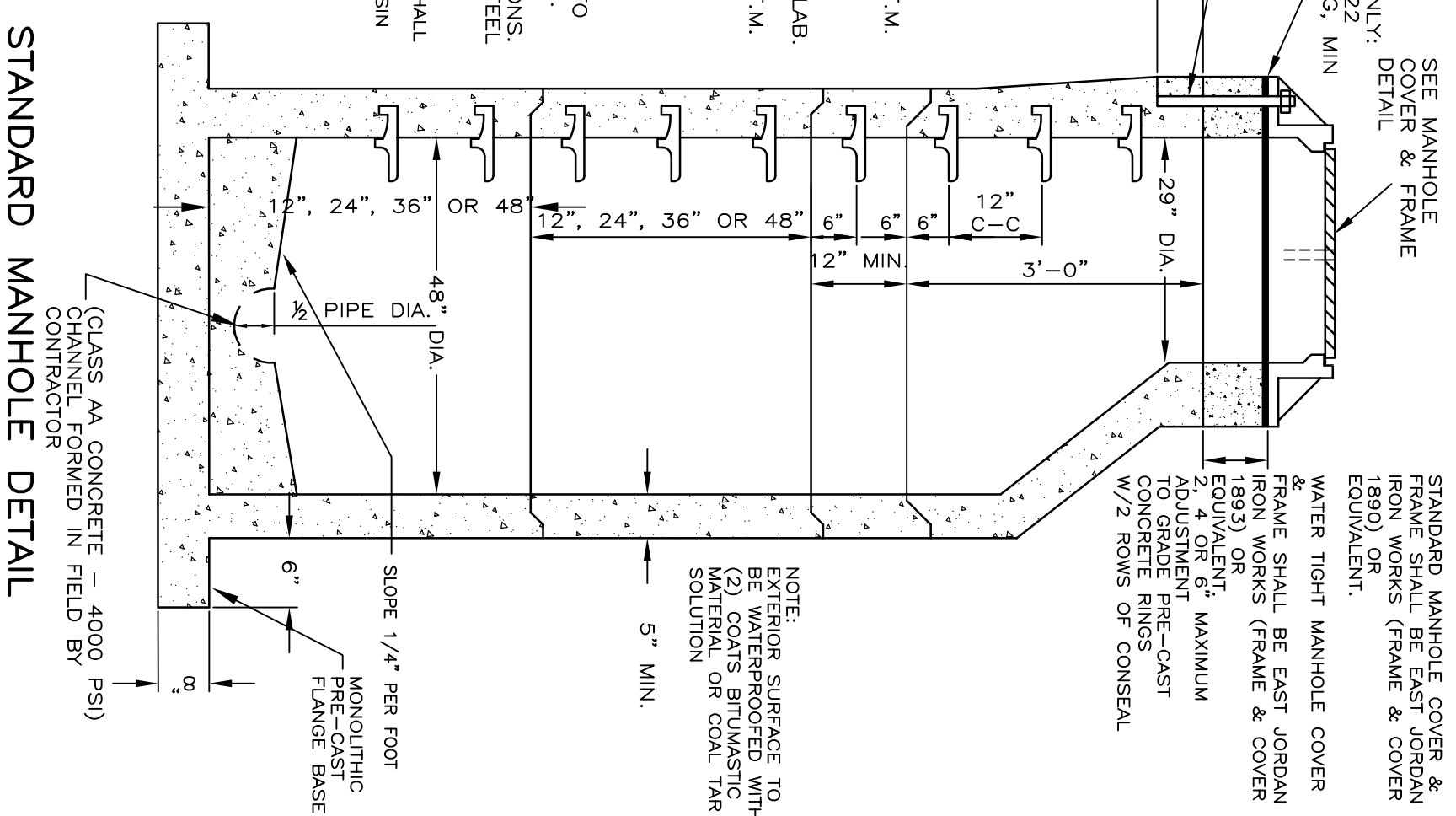

- GENERAL NOTES:**
1. REINFORCED STEEL A.S.T.M. A195 SPEC. 0.24 SQ. IN./LINEAL FT. IN 96\"/>
  - 2. REINFORCED STEEL A.S.T.M. A195 SPEC. 0.24 SQ. IN. BARREL AND 0.24 SQ. IN. REINFORCED STEEL SLAB CONFORMS TO LATEST A.S.T.M. A195 SPEC. 0.12 SQ. IN. BARREL A.S.T.M. IN 48\"/>
  - 3. CONCRETE COMPRESSIVE STRENGTH CLASS 4,000 PSI
  - 4. MANHOLE DESIGN SPECIFICATIONS CONFORM TO PRECAST MANHOLE SECTIONS, ATTENTIVE TO SLAB IS STEEL EXCEED HS-20 LOADING
  - 5. SANDWICH MANHOLE JOINTS SHALL BE SEALED WITH 2 ROWS OF RESIN SEALANT EACH JOINT

**NOTE:**  
WATER TIGHT MANHOLE, FRAME, AND COVER WHERE REQUIRED SHALL BE EAST JORDAN IRON WORKS INC. FRAME & COVER SHALL BE EAST JORDAN IRON WORKS INC. FRAME & COVER 1890 OR EQUIVALENT

**GENERAL NOTES:**  
CURB SECTIONS TO BE TO LENGTHS 1/2\"/>

**BITUMINOUS PAVEMENT REPLACEMENT INCLUDED UNDER BID ITEM # 5**  
NOT TO SCALE

PIECE NO.	QUANTITY	DESCRIPTION
1	101 (110)	TOOK
2	141 (110)	TOOK
3	141 (110)	TOOK
4	141 (110)	TOOK
5	141 (110)	TOOK
6	141 (110)	TOOK
7	141 (110)	TOOK
8	141 (110)	TOOK
9	141 (110)	TOOK
10	141 (110)	TOOK
11	141 (110)	TOOK
12	141 (110)	TOOK
13	141 (110)	TOOK
14	141 (110)	TOOK
15	141 (110)	TOOK
16	141 (110)	TOOK
17	141 (110)	TOOK
18	141 (110)	TOOK
19	141 (110)	TOOK
20	141 (110)	TOOK
21	141 (110)	TOOK
22	141 (110)	TOOK
23	141 (110)	TOOK
24	141 (110)	TOOK
25	141 (110)	TOOK
26	141 (110)	TOOK
27	141 (110)	TOOK
28	141 (110)	TOOK
29	141 (110)	TOOK
30	141 (110)	TOOK
31	141 (110)	TOOK
32	141 (110)	TOOK
33	141 (110)	TOOK
34	141 (110)	TOOK
35	141 (110)	TOOK
36	141 (110)	TOOK
37	141 (110)	TOOK
38	141 (110)	TOOK
39	141 (110)	TOOK
40	141 (110)	TOOK
41	141 (110)	TOOK
42	141 (110)	TOOK
43	141 (110)	TOOK
44	141 (110)	TOOK
45	141 (110)	TOOK
46	141 (110)	TOOK
47	141 (110)	TOOK
48	141 (110)	TOOK
49	141 (110)	TOOK
50	141 (110)	TOOK
51	141 (110)	TOOK
52	141 (110)	TOOK
53	141 (110)	TOOK
54	141 (110)	TOOK
55	141 (110)	TOOK
56	141 (110)	TOOK
57	141 (110)	TOOK
58	141 (110)	TOOK
59	141 (110)	TOOK
60	141 (110)	TOOK
61	141 (110)	TOOK
62	141 (110)	TOOK
63	141 (110)	TOOK
64	141 (110)	TOOK
65	141 (110)	TOOK
66	141 (110)	TOOK
67	141 (110)	TOOK
68	141 (110)	TOOK
69	141 (110)	TOOK
70	141 (110)	TOOK
71	141 (110)	TOOK
72	141 (110)	TOOK
73	141 (110)	TOOK
74	141 (110)	TOOK
75	141 (110)	TOOK
76	141 (110)	TOOK
77	141 (110)	TOOK
78	141 (110)	TOOK
79	141 (110)	TOOK
80	141 (110)	TOOK
81	141 (110)	TOOK
82	141 (110)	TOOK
83	141 (110)	TOOK
84	141 (110)	TOOK
85	141 (110)	TOOK
86	141 (110)	TOOK
87	141 (110)	TOOK
88	141 (110)	TOOK
89	141 (110)	TOOK
90	141 (110)	TOOK
91	141 (110)	TOOK
92	141 (110)	TOOK
93	141 (110)	TOOK
94	141 (110)	TOOK
95	141 (110)	TOOK
96	141 (110)	TOOK
97	141 (110)	TOOK
98	141 (110)	TOOK
99	141 (110)	TOOK
100	141 (110)	TOOK

PIECE NO.	QUANTITY	DESCRIPTION
1	101 (110)	TOOK
2	141 (110)	TOOK
3	141 (110)	TOOK
4	141 (110)	TOOK
5	141 (110)	TOOK
6	141 (110)	TOOK
7	141 (110)	TOOK
8	141 (110)	TOOK
9	141 (110)	TOOK
10	141 (110)	TOOK
11	141 (110)	TOOK
12	141 (110)	TOOK
13	141 (110)	TOOK
14	141 (110)	TOOK
15	141 (110)	TOOK
16	141 (110)	TOOK
17	141 (110)	TOOK
18	141 (110)	TOOK
19	141 (110)	TOOK
20	141 (110)	TOOK
21	141 (110)	TOOK
22	141 (110)	TOOK
23	141 (110)	TOOK
24	141 (110)	TOOK
25	141 (110)	TOOK
26	141 (110)	TOOK
27	141 (110)	TOOK
28	141 (110)	TOOK
29	141 (110)	TOOK
30	141 (110)	TOOK
31	141 (110)	TOOK
32	141 (110)	TOOK
33	141 (110)	TOOK
34	141 (110)	TOOK
35	141 (110)	TOOK
36	141 (110)	TOOK
37	141 (110)	TOOK
38	141 (110)	TOOK
39	141 (110)	TOOK
40	141 (110)	TOOK
41	141 (110)	TOOK
42	141 (110)	TOOK
43	141 (110)	TOOK
44	141 (110)	TOOK
45	141 (110)	TOOK
46	141 (110)	TOOK
47	141 (110)	TOOK
48	141 (110)	TOOK
49	141 (110)	TOOK
50	141 (110)	TOOK
51	141 (110)	TOOK
52	141 (110)	TOOK
53	141 (110)	TOOK
54	141 (110)	TOOK
55	141 (110)	TOOK
56	141 (110)	TOOK
57	141 (110)	TOOK
58	141 (110)	TOOK
59	141 (110)	TOOK
60	141 (110)	TOOK
61	141 (110)	TOOK
62	141 (110)	TOOK
63	141 (110)	TOOK
64	141 (110)	TOOK
65	141 (110)	TOOK
66	141 (110)	TOOK
67	141 (110)	TOOK
68	141 (110)	TOOK
69	141 (110)	TOOK
70	141 (110)	TOOK
71	141 (110)	TOOK
72	141 (110)	TOOK
73	141 (110)	TOOK
74	141 (110)	TOOK
75	141 (110)	TOOK
76	141 (110)	TOOK
77	141 (110)	TOOK
78	141 (110)	TOOK
79	141 (110)	TOOK
80	141 (110)	TOOK
81	141 (110)	TOOK
82	141 (110)	TOOK
83	141 (110)	TOOK
84	141 (110)	TOOK
85	141 (110)	TOOK
86	141 (110)	TOOK
87	141 (110)	TOOK
88	141 (110)	TOOK
89	141 (110)	TOOK
90	141 (110)	TOOK
91	141 (110)	TOOK
92	141 (110)	TOOK
93	141 (110)	TOOK
94	141 (110)	TOOK
95	141 (110)	TOOK
96	141 (110)	TOOK
97	141 (110)	TOOK
98	141 (110)	TOOK
99	141 (110)	TOOK
100	141 (110)	TOOK

PIECE NO.	QUANTITY	DESCRIPTION
1	101 (110)	TOOK
2	141 (110)	TOOK
3	141 (110)	TOOK
4	141 (110)	TOOK
5	141 (110)	TOOK
6	141 (110)	TOOK
7	141 (110)	TOOK
8	141 (110)	TOOK
9	141 (110)	TOOK
10	141 (110)	TOOK
11	141 (110)	TOOK
12	141 (110)	TOOK
13	141 (110)	TOOK
14	141 (110)	TOOK
15	141 (110)	TOOK
16	141 (110)	TOOK
17	141 (110)	TOOK
18	141 (110)	TOOK
19	141 (110)	TOOK
20	141 (110)	TOOK
21	141 (110)	TOOK
22	141 (110)	TOOK
23	141 (110)	TOOK
24	141 (110)	TOOK
25	141 (110)	TOOK
26	141 (110)	TOOK
27	141 (110)	TOOK
28	141 (110)	TOOK
29	141 (110)	TOOK
30	141 (110)	TOOK
31	141 (110)	TOOK
32	141 (110)	TOOK
33	141 (110)	TOOK
34	141 (110)	TOOK
35	141 (110)	TOOK
36	141 (110)	TOOK
37	141 (110)	TOOK
38	141 (110)	TOOK
39	141 (110)	TOOK
40	141 (110)	TOOK
41	141 (110)	TOOK
42	141 (110)	TOOK
43	141 (110)	TOOK
44	141 (110)	TOOK
45	141 (110)	TOOK
46	141 (110)	TOOK
47	141 (110)	TOOK
48	141 (110)	TOOK
49	141 (110)	TOOK
50	141 (110)	TOOK
51	141 (110)	TOOK
52	141 (110)	TOOK
53	141 (110)	TOOK
54	141 (110)	TOOK
55	141 (110)	TOOK
56	141 (110)	TOOK
57	141 (110)	TOOK
58	141 (110)	TOOK
59	141 (110)	TOOK
60	141 (110)	TOOK
61	141 (110)	TOOK
62	141 (110)	TOOK
63	141 (110)	TOOK
64	141 (110)	TOOK
65	141 (110)	TOOK
66	141 (110)	TOOK
67	141 (110)	TOOK
68	141 (110)	TOOK
69	141 (110)	TOOK
70	141 (110)	TOOK
71	141 (110)	TOOK
72	141 (110)	TOOK
73	141 (110)	TOOK
74	141 (110)	TOOK
75	141 (110)	TOOK
76	141 (110)	TOOK
77	141 (110)	TOOK
78	141 (110)	TOOK
79	141 (110)	TOOK
80	141 (110)	TOOK
81	141 (110)	TOOK
82	141 (110)	TOOK
83	141 (110)	TOOK
84	141 (110)	TOOK
85	141 (110)	TOOK
86	141 (110)	TOOK
87	141 (110)	TOOK
88	141 (110)	TOOK
89	141 (110)	TOOK
90	141 (110)	TOOK
91	141 (110)	TOOK
92	141 (110)	TOOK
93	141 (110)	TOOK
94	141 (110)	TOOK
95	141 (110)	TOOK
96	141 (110)	TOOK
97	141 (110)	TOOK
98	141 (110)	TOOK
99	141 (110)	TOOK
100	141 (110)	TOOK

DATE: 03/19/2025

APPROVED BY: R. E. Z.

DRAWN BY: RANDY